

Installation and Maintenance

OCS Half-Moon Rotary Energy Exchanger

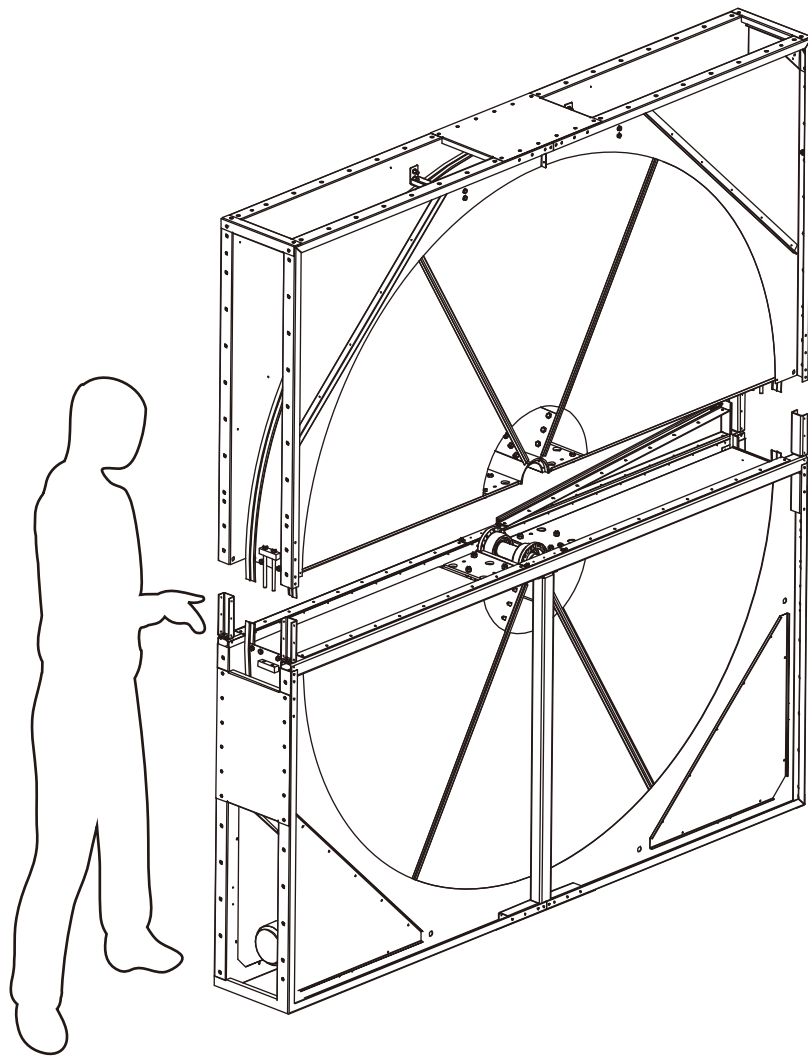

Table of Contents

1 Introduction	3
Principles of Rotary Energy Exchanger	
2 Prior Installation	4
3 Specifications	
Order Key	5
4 Safety and Warning	6
5 Storage	6
6 Tools and Aids	7
7 Packing List	8
8 Installation	
8.1 Dismantling of the package	9
8.2 Checking the air direction	10
8.2 Bottom Part	11
8.3 Top Part	12
8.4 Top Part and Bottom Part	13
8.5 HUB, Periphery and Radial walls	14
8.6 Brush sealing and Middle Connector	15
8.7 Connection bracket, HUB and Center plate	16
8.8 Purge Sector	16
8.9 Drive Belt	17
8.10 Cover Plate	17
9 Start-up	
9.1 Inspection	18
9.2 Check List	18
10 Maintenance	19
11 Warranty	20

Rotary Energy Exchanger Casing / Cassette installation guidelines

Ostberg standard casing / cassettes shall be installed inside an air handler, within a duct system if the Rotary Energy Exchanger shall be used as a "stand alone" component it must be announced at order. A stand-alone unit must be properly secured. Optional, a standard unit can be delivered with proper exterior cover, insulation and waterproof.

Casing / Cassette installation must ensure that the rotor and drive is protected from foreign elements and provided with enough structure to adequately support the cassette from disorienting during operation.

Access doors shall be provided to allow for casing / cassette and drive maintenance, as well as rotor removal. At a minimum, the full height of the drive end and 0.6m before and after the casing / cassette shall be accessible for maintenance and service. This to provide full access to the sealing on the middle beam, full access to the attachment of the rotor to the framework.

Dividing wall between supply and exhaust air channels shall be designed to consider access to the attachment points to the center of shaft, shaft support area (shaft bolts) to the frame.

Provide clearance to adjacent walls or equipment to provide a minimum of one rotor diameter from the opening of casing / cassette frame up to a rotor \varnothing of 2000 mm. For larger rotor \varnothing half of the rotor \varnothing is requested for service area outside the unit.

Vertical installation, the casing / cassette is as standard build for vertical installation. If the unit is "stand-alone" the unit must be secured to avoid any safety risk during installation and operation.

Horizontal installation is possible for rotors up to diameter 3500 mm. However, all horizontal applications request a center support along the whole middle beam and all 4 full sides of the cassette. The support structure must be provided by the buyer.

Casing / Cassette attachment Casing / Cassette attachment within an air handler may be by bolting, riveting or screwing. Note that the casing / cassette must be installed with care, when drilling, exercise caution not to damage rotor seals, rotor face or rotating parts. All attachment within the air handler should be additionally sealed to prevent leakage between the air streams. Attachment should result in that the casing / cassette is mounted without distortion of the frame of the casing / cassette. Distortion of the casing / cassette from improper installation may result in substantially unequal clearance between the rotor face and the casing / cassette. This can cause excessive drive torque requirements, causing increased wear and tear to drive, seals and rotor.

**TO ENSURE TROUBLE-FREE STARTUP IT'S IMPORTANT TO FOLLOW
THE INSTRUCTIONS IN THIS MANUAL**

- A At receiving of the delivery check that there's no damages on the packing. Damages on the packing shall be reported to the forwarder directly at the receiving all visible damages on the package **MUST** be noted on the delivery note.
- B TILT WATCH is used to verify a normal handling of the goods during shipment. If the TILT WATCH is activated the unit shall be deemed as defect and directly reported to the forwarder and Seller (verify with photo). If the Tilt watch is activated the unit has been exposed for unreasonable large force or un-normal handling during transportation.
- C The unit shall remain in its original packing until installation. Dry intermediate storage of the delivered equipment is in any case required.
- D Do not remove the package until the unit is directly close to the location of installation, and the Air Handling Unit is ready for the unit.
- E Keep the unit inside the packing during transportation at the site.
- F Do not remove the protection of the rotor surface until final until commissioning.
- G The unit is in standard performance made for vertical installation. Unit for horizontal installation can be offered upon request.
- H Ensure that the unit is installed on an even base so that the rotor is aligned in the casing.
- I If the unit is equipped with PURGE SECTOR, ensure that the purge sector is placed in the correct position. Please see section Installation type and Motor position.
- J Some casings allow direct connection to duct system. This type of application demands that the load from the duct system is neutralized at the connection point to the casing so that no load from the duct is transferred to the casing structure.
- K Ensure that Drive motor is easily accessible. Electrical connection is to be provided by the buyer.
- L Service doors shall be provided so that the unit is fully accessible for maintenance work.
- M NOTES adjustment of the rotor position may be required. Always check the alignment of the rotor at start-up to ensure that the rotor face is parallel to the casing / cassette frame and face panels.

SPECIFICATION

HOW TO READ THE ORDER KEY

-[1] - [2] - [3] - [4] - [5] - [6] - [7] - [8] - [9]

Rotor material

Well height

Rotor

Rotor diameter

Casing

Rotor depth

Drive equipment

Installation type

Motor position

Example: Ostberg OM-N-W-1500-OCS-200-K-A-1

SYMBOLS

[1] Rotor material	OT OE OC OK OH OM	- Untreated aluminum foil - Oxidized aluminum foil - Epoxy-coated foil - Seawater corrosion resistant aluminium alloy (5052) foil - 3A molecular sieve and untreated aluminum foil - 3A molecular sieve
[2] Well height	XL SL L N H	- Extra Low - Special Low - Low - Normal - High
[3] Rotor	W S	- Winded rotor - Sectorized rotor
[4] Rotor diameter in mm		see "Dimensions"
[5] Casing	OCS / H DS / H	- In accordance with "Dimensions" - In accordance with "Dimensions"
[6] Rotor depth in mm	250 200 150 100	250 mm 200 mm (Standard) 150 mm 100 mm
[7] Drive equipment	V K	- Variable drive, MicroMax - Constant drive
[8] Installation type	A,B,C,D,E,F...P (Installation type and motor position)	
[9] Motor position	1,2,3,4 (Installation type and motor position)	

Accessories
 *Powder coated sheet metal, *Drain pan

Optional
 *Insulation and *SST 304 complete casing



WARNING RISK OF INJURY

The unit has to be secured in order to prevent accidents.

- Installation must be carried out by professionals.
- Please read through this manual carefully before installation and follow it strictly to avoid injury.



WARNING FALLING OBJECTS



Check that the consignment matches your order and that the goods have not been damaged during the transportation.

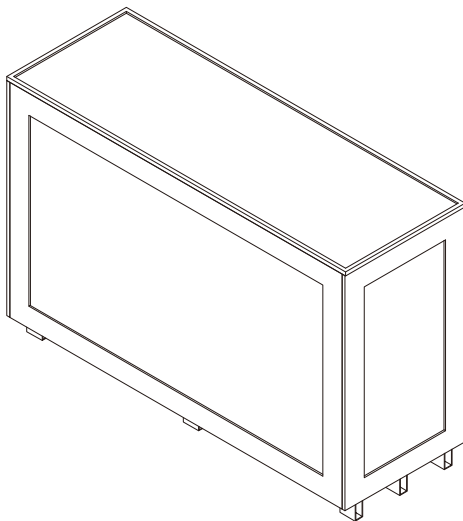

- If the Rotary Energy Exchanger is not installed immediately, it should be stored in its original packaging, standing on a flat surface and protected from rain and direct sunlight.
- To avoid damages, the Rotary Energy Exchanger should be transported and handled in a vertical position.

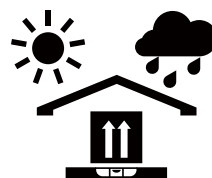

TOOLS AND AIDS

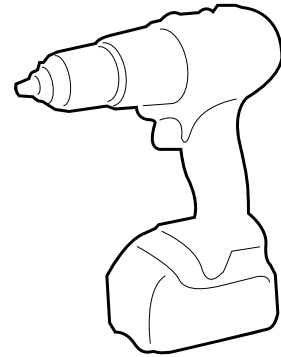
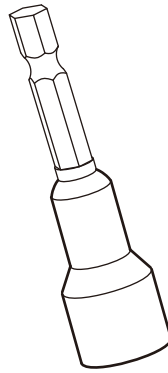
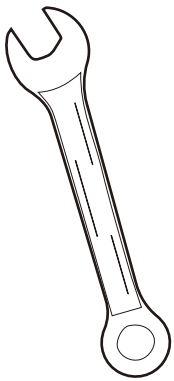

Tools list	Applicable object
Wrenches 17#:	M10-Outer Hexagon Nut
Wrenches 16#:	M10-Outer Hexagon Bolt
Wrenches 13#	M8-Outer Hexagon Bolt
Inner hexagon 8# wrenches	M10-Inner hexagonal bolt
Inner hexagon 6# wrenches	M8-Inner hexagonal bolt
Plum Blossom Batch T4	M5-Center cover plum countersunk bolt
Hexagonal batch 8mm	Remove the transportation anchor
Hexagonal batch 1/4#	Remove the transportation anchor
Electric driller	Remove the transportation anchor
Screw driver	Connect drive belt
Riveter	4.8*10, 4.8x14 rivet

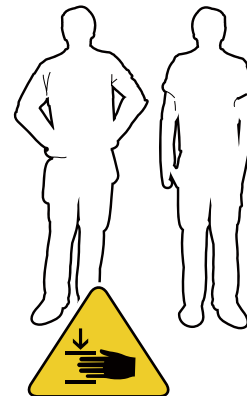
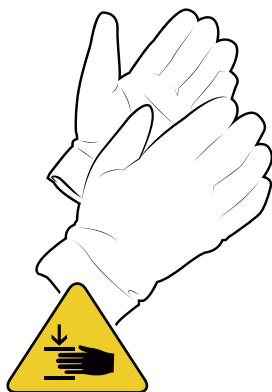

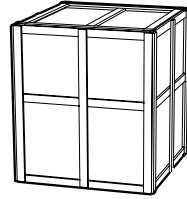







WHAT IS INCLUDED UPON DELIVERY

NO.	NAME	Q'TY	UNIT	REMARK
1	Bottom part rotor	1	pcs	Rotary Energy Exchanger unit With drive unit
2	Top part rotor	1	pcs	Rotary Energy Exchanger unit
3	Center plate	2	set	4 halfmoons
4	Cover plate	1	kit	Optional
5	Purge sector	1	kit	Depends on customer's requirements, if installed separately on site
6	Assembling kit	1	kit	Carton box

Assembling kit list

NO.	DISCRIPTION	Q'TY(pcs)	TORQUE(Nm)	REMARK	
1	Bolt M10x140-Outer Hexagon Bolt	4	20	Open wrenches 17#	
2	Bolt M10x35	4	15	Inner hexagon wrenches 8#	
3	Bolt M8x20	10	13	Inner hexagon wrenches 6#	
4	Bolt M5x10	24	6	Plum Blossom Batch T4	
5	Nut M10	8		Open wrenches 16#	
6	Lifting ring	2			
7	M10 Washer	8			
8	Rivet	1 set			
9	Drive belt	1		With buckle	
10	Loctite	1			
11	Installation manual	1			

Installation way

1. Lift and install the bottom part in the AHU first, then lift and install the top part.
2. Assembling the upper and lower part outside of the AHU, then lift it into the AHU.

Dismantling package

Place the package as close as possible to the location of installation before dismantling/opening the package.

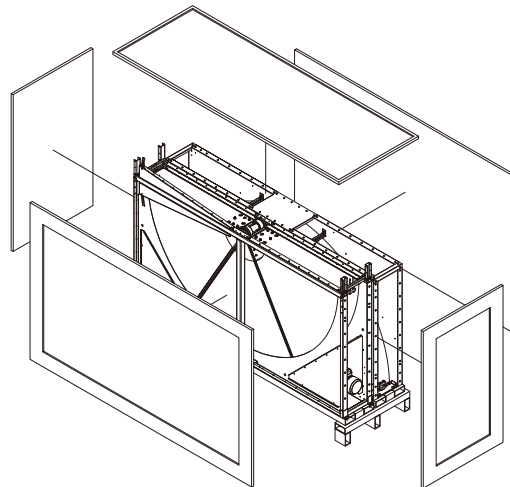
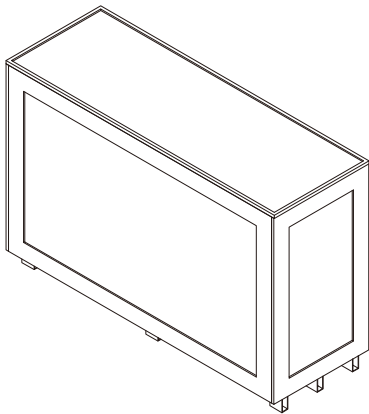

Step 1

Fix the two lift straps through the HUB under the midbeam on each side of support leg, the lift straps should follow the local regulations. (Do not lift in the shaft).

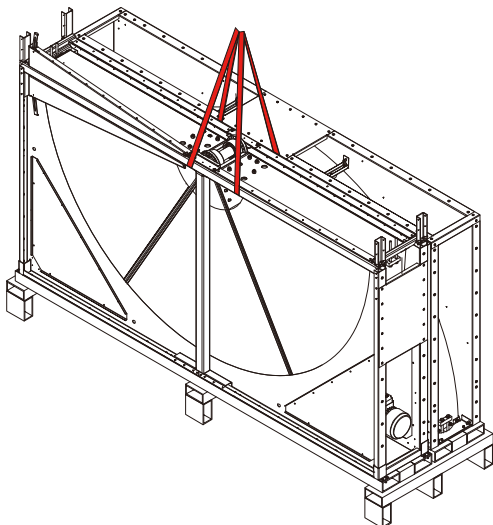

Step 2

Remove the two transportation anchors screws that are used to fix the bottom part with the pallet. DO NOT remove the two transportation anchors that are used to fix the top part with the pallet.

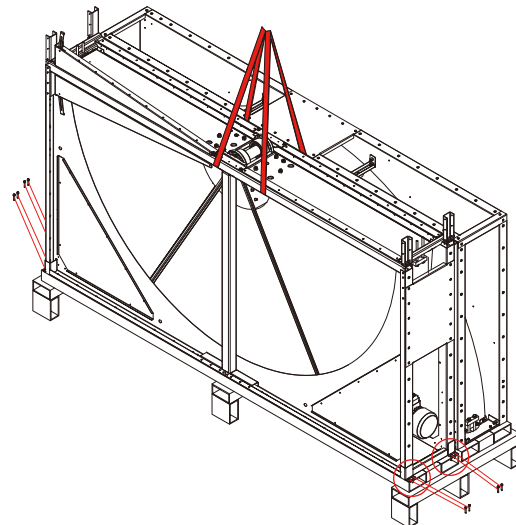

Step 3

Check that the supply air and exhaust air direction are following AHU design and motor position is correct. The direction is determined by following below schema.

INSTALLATION TYPE and MOTOR POSITION

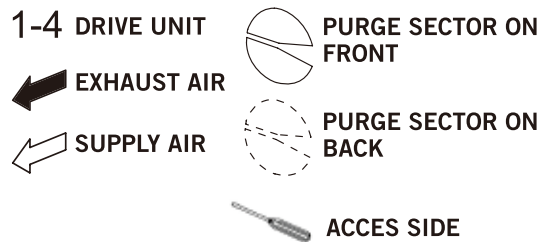
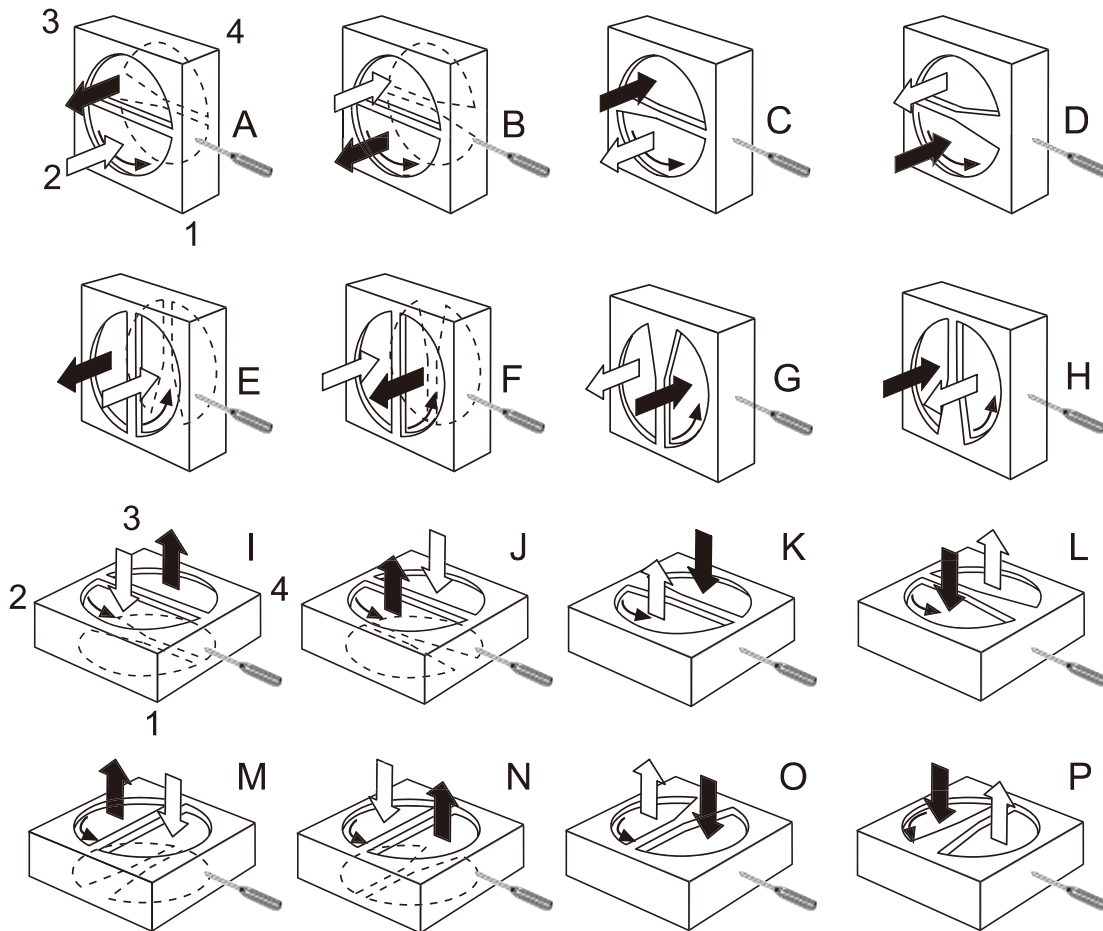

Step 4

- During lifting process, please follow the local regulations.
- Ensure that the unit is installed on an even base so that the rotor is aligned with the casing.

4. Lift the bottom part to the right location.

4.1 Before lift the bottom part into the AHU, ensure that the air direction is correspond to the air direction of AHU.

4.2 Pls Check the motor position corresponded to the AHU service access. If not pls contact the AHU manufacturer.

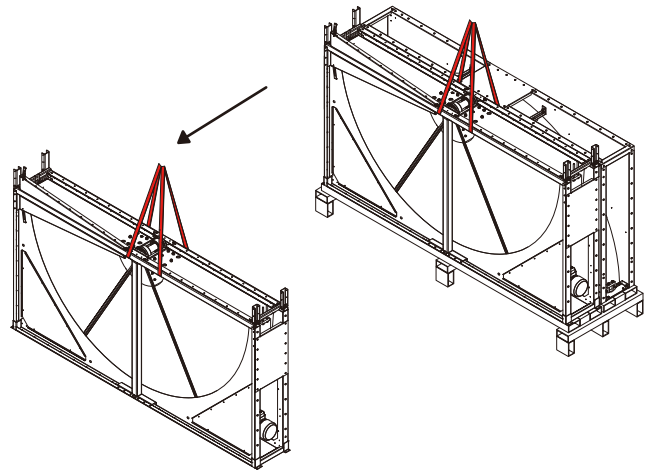
Step 5-6

5. Remove bottom part anchors.

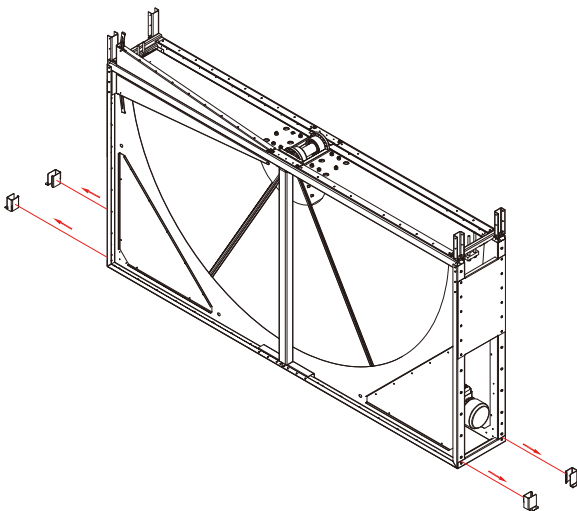

6. Remove the two sides metal-brackets at the top of the bottom part.

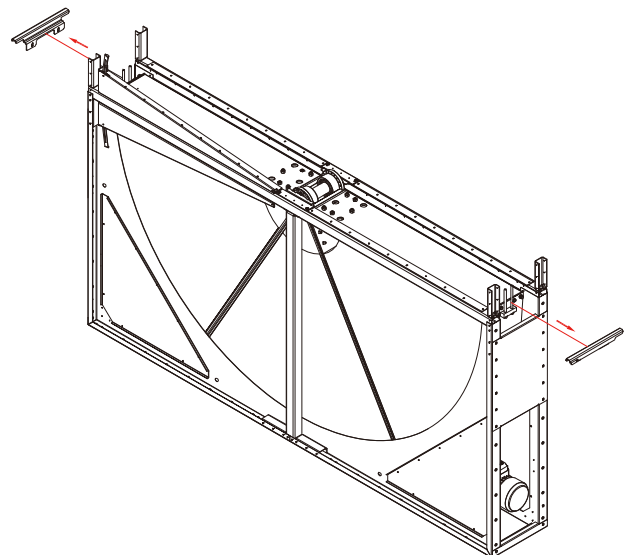

Step 7-8

7. Fix the two lift straps through the casing frame at the top of top part.
8. Remove the two transportation anchors that are used to secure top part with the pallet.

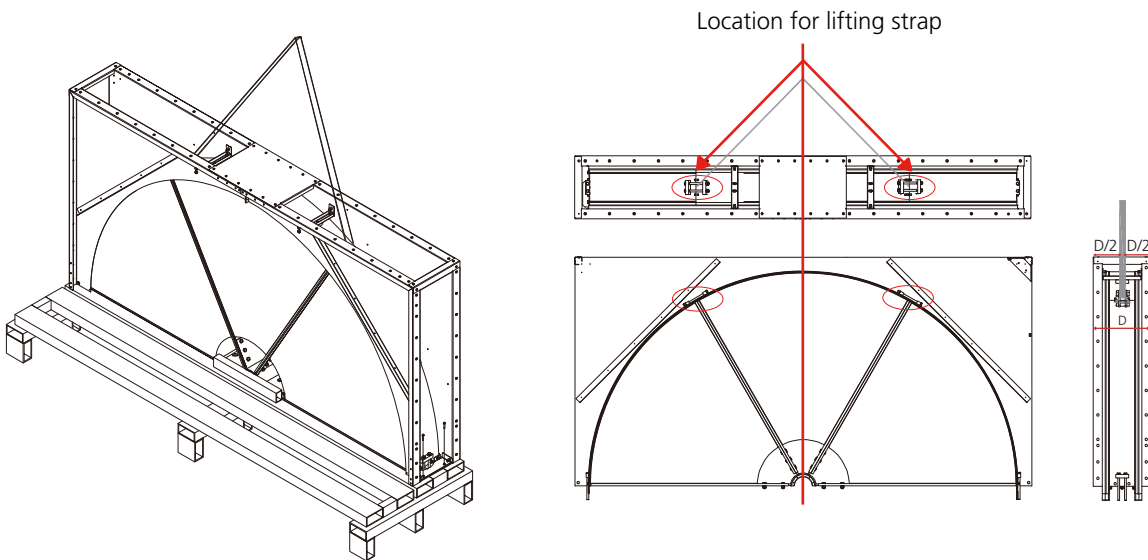
Step 9

9. Lift the top part to the correct position keep 150-200mm to the bottom part.



- Make sure the top part is in balance.
- Before positioning the top part ensure that the positioning indicate A is at the same side.

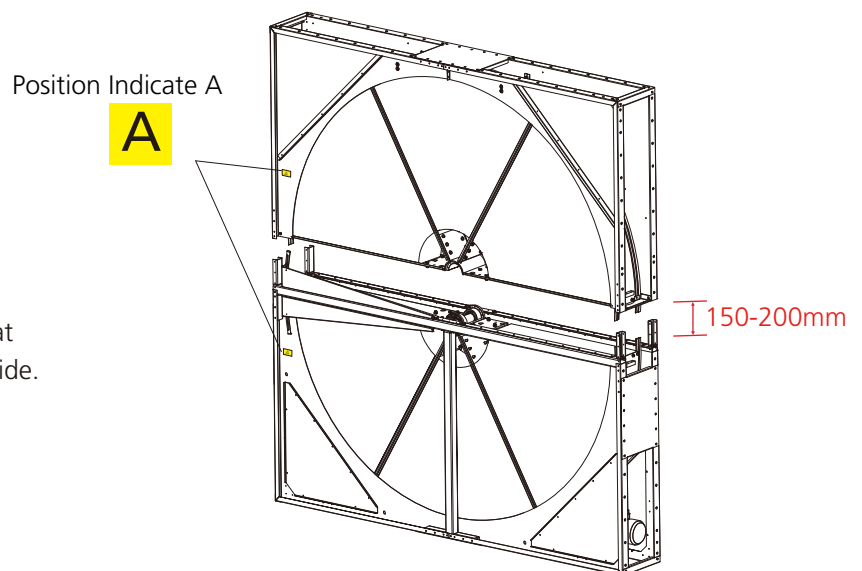

Step 10-12

10. Remove the two support brackets from the top part.
11. Lower the top part carefully to correct position it on with the bottom part.
12. Remove middle cover plate from bottom part.

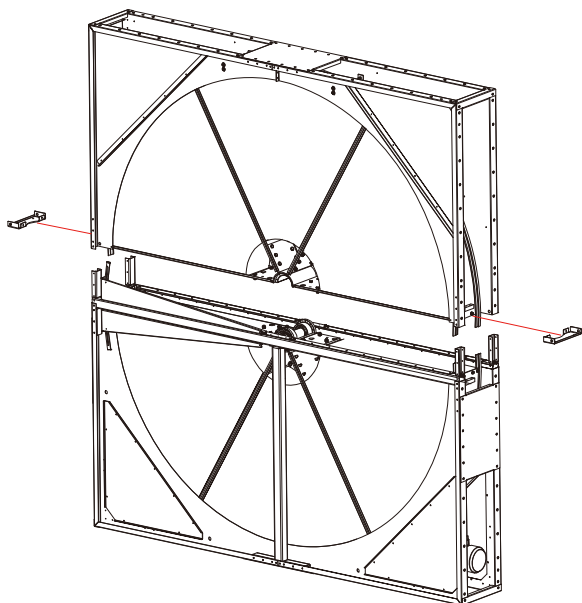

Step 10

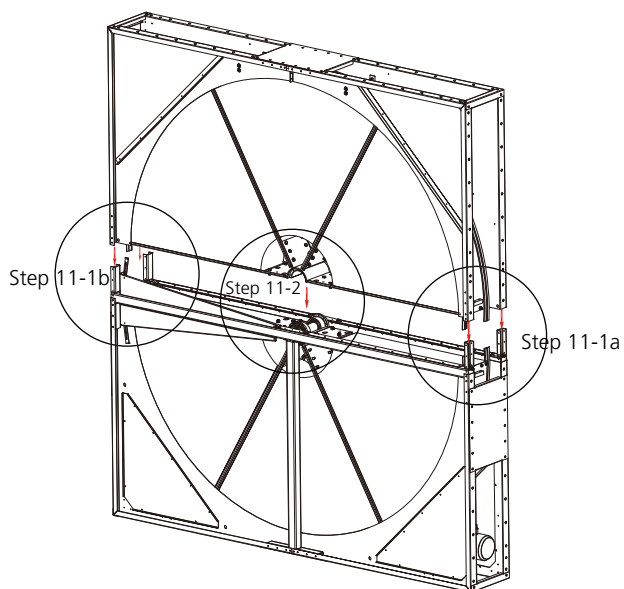

Step 11

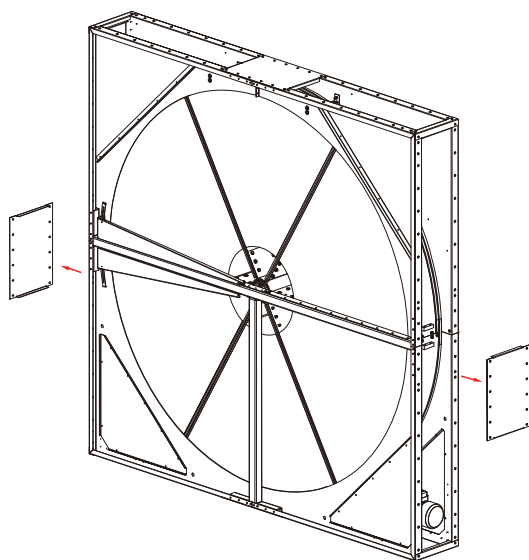

Step 12

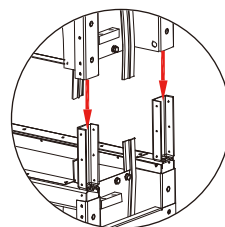

Step 11-1a
Step 11-1b

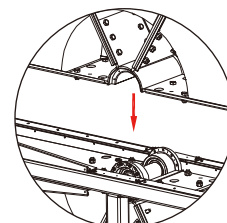

Step 11-2

Step 13-15

13. Fix top part on the T support with rivet.



4.8x14 rivet

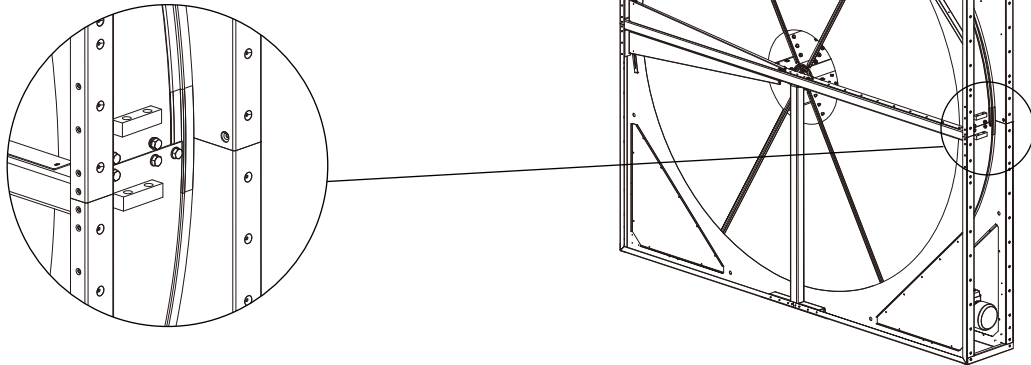

14. Loctite M8*20 (13Nm) bolt to connect HUB and bearing ring, and tighten.

15. Use M10*35 bolt with nut to connect the top and bottom HUB wings.

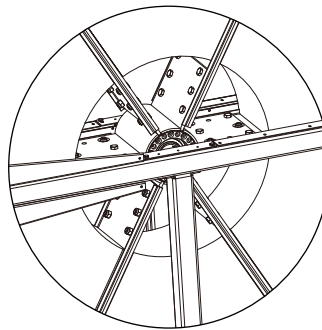
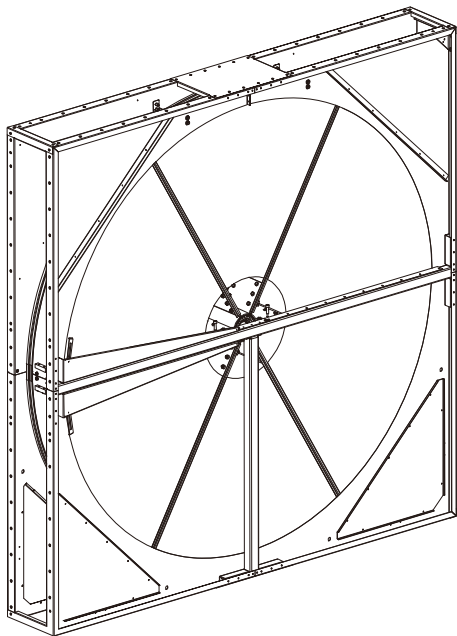

1



M8*20 (13 Nm)
3pcs on each side,
the rest 2pcs on **step 18**

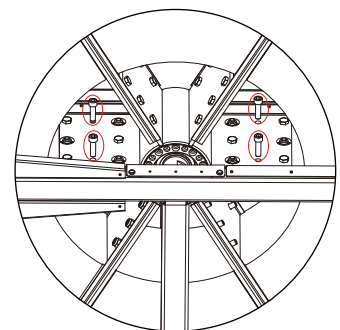

2



M10*35
(15 Nm)

Step 16-18

16. Use M10*140(20 Nm) bolt with nut, tighten the periphery on left and right side.

17. Overlap the ends of the brush sealing, if needed, secure with self-tapping screws.

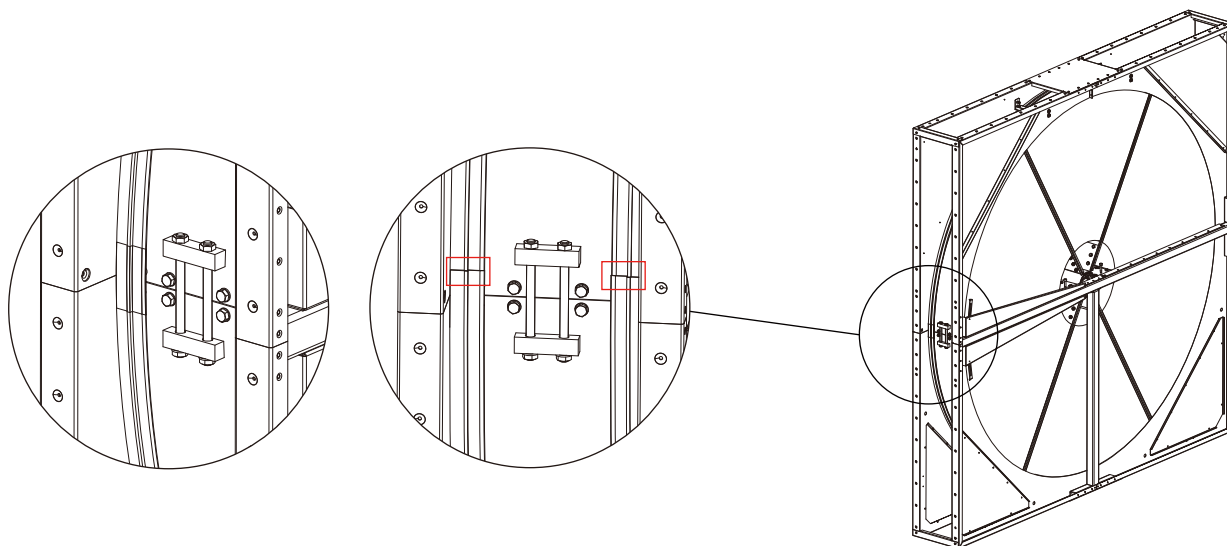

18. Install middle cover plate on correct position.

The middle cover plate with airflow direction sign is installed on the side of motor.

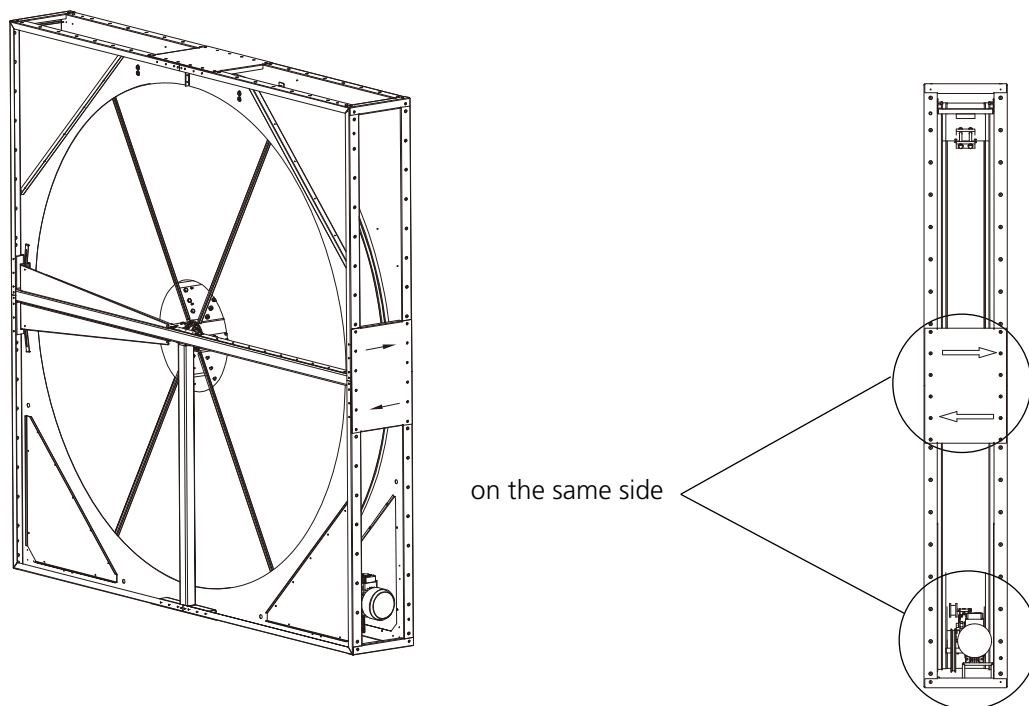

Step 19-20

19. Remove the two connection brackets on the top of the unit.
20. Rotate the rotor to locate the remaining bearing ring bolt M8*20.

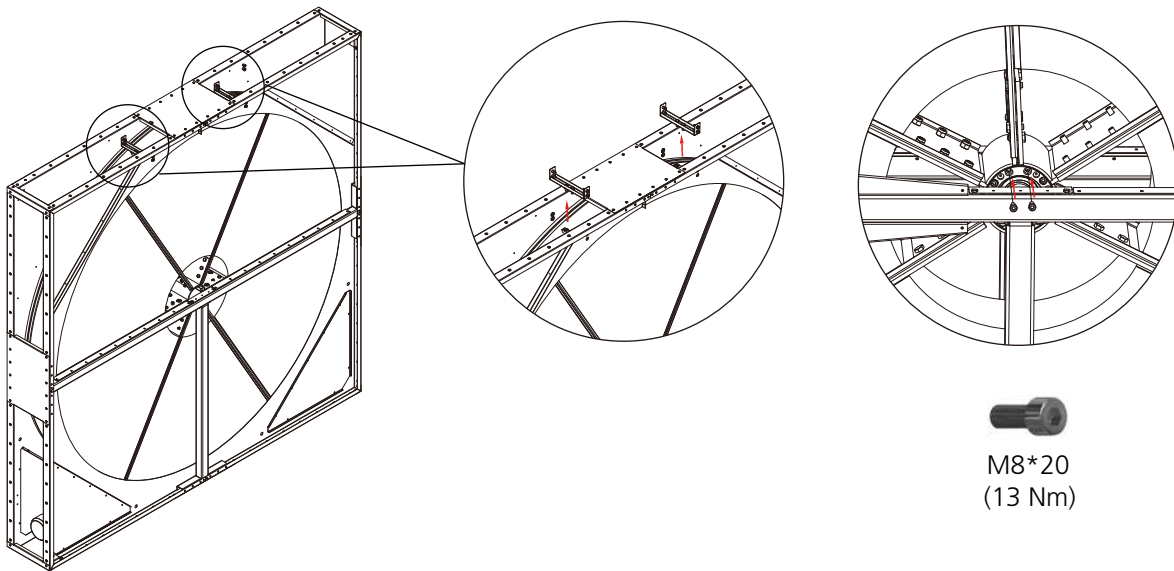
**Step 21-22**

21. Rotate the rotor to get access to M5 holes in the bearing ring to attach the center plates.
22. The purge sector should be on the supply air side. Please refer to Step 3.

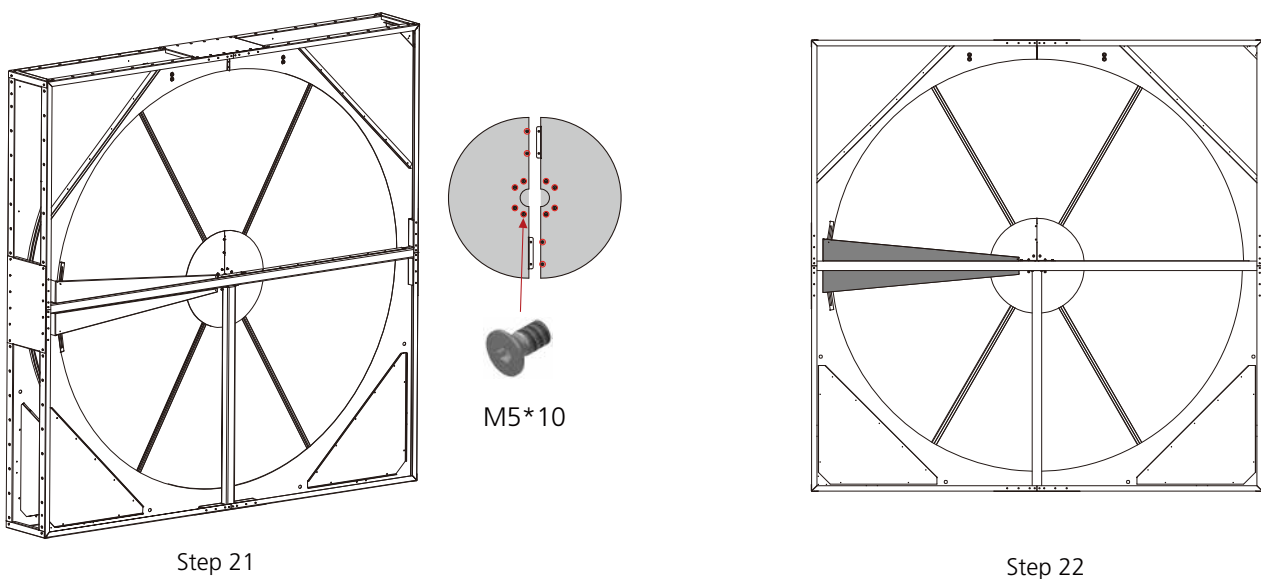

Step 23-24

Drive belt connection

- The drive belt is ready to use, DO NOT adjust the length.
23. Put one end of drive belt between periphery and tension bolt, rotate the rotor while positioning drive belt.
24. Put the drive belt on the pulley, positioning the drive belt on the belt tensioner.

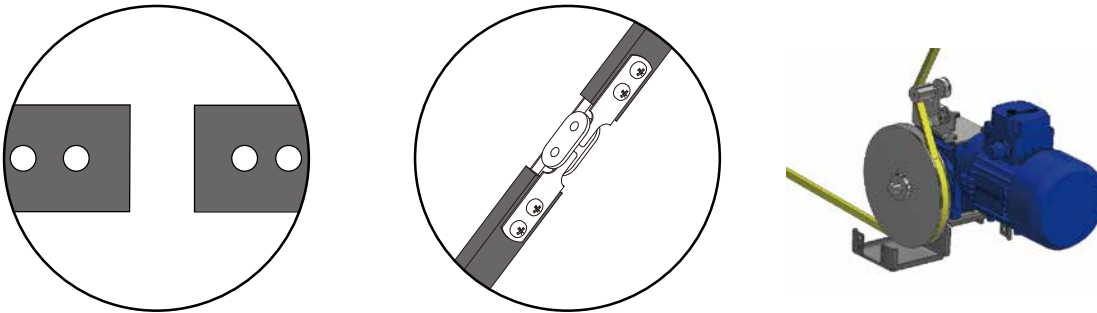

Step 25-26

25. Connect the motor with correct power, and check so the rotation direction is correct as shown by the label on the rotor.
26. Cover plate is optional, fix the cover plate with 4.8*10 rivets on both sides and top side.

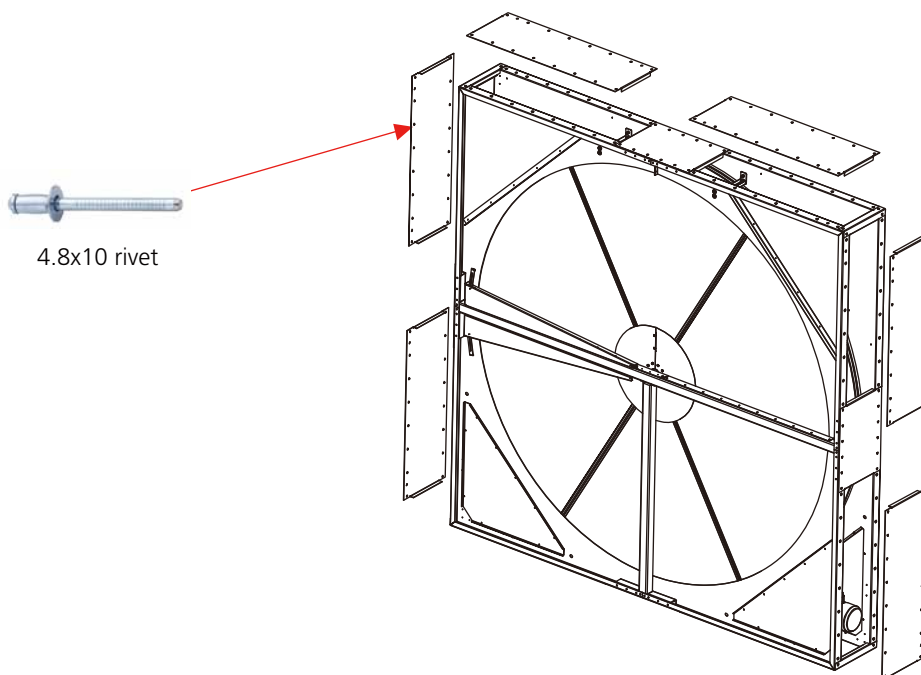

- Inspect the Energy Recovery Casing / Cassette to ensure that it is securely mounted within the air handler and that there is no distortion of the framework.
- The rotor should be centered within the casing / cassette frame to prevent it from contacting the support structure and turn freely with light force.
- Brush seal should be adjusted before commissioning , visually slightly touching the wheel surface without gaps while rotating.
- Distortion of the casing / cassette from improper installation or shipping and transportation may result in substantially unequal clearance between the rotor face and the casing / cassette. This will lead to excessive drive torque requirement reduce in the life of the drive components, result in belt and pulley wear, uneven seal wear, and reduced sale or media life time.
- Tension all the tension bolts of a circle(1) for 30Nm.
Tension all the tension bolts of a circle(2) for 40Nm.
Tension all the tension bolts of a circle(3) for 50Nm.
- Inspect the drive system to ensure that the drive motor and pulley is securely installed.
- The drive belt should be taut and align properly with the drive pulley and perimeter of the rotor.
- Verify proper supply voltage to the drive motor prior to energizing the drive system.
- Energize the drive motor and verify proper rotation and rotation speed. Sensible rotors shall turn 10 – 12 rpm while Sorption rotors shall turn 18-22rpm (if constant drive).
- If the unit is equipped with a purge sector verify that the rotor is turning in the correct direction. If the unit isn't equipped with purge sector the rotation can be in either directions. Air flow shall always be in "CONTRA FLOW" directions.

Check List

1	Casing / Cassette installed properly and sealed between the air streams	<input type="checkbox"/>
2	Access to the drive system	<input type="checkbox"/>
3	Access to the center support shaft / bolts	<input type="checkbox"/>
4	Access to sealing along the periphery	<input type="checkbox"/>
5	Access to sealing along the middle beam on both sides of the rotor face	<input type="checkbox"/>
6	Seals contact periphery / face of the rotor	<input type="checkbox"/>
7	Rotor turns freely	<input type="checkbox"/>
8	Drive motor and pulley properly installed and secured	<input type="checkbox"/>
9	Drive belt property tensioned	<input type="checkbox"/>
10	Verify correct voltage to the drive system	<input type="checkbox"/>
11	Correct direction of rotation	<input type="checkbox"/>
12	Correct location of Purge sector (if any)	<input type="checkbox"/>

Routine Maintenance and Inspection

The rotor and casing / Casstte require little in the way of routine maintenance. Following periodic inspections are required.

Routine Maintenance Schedule

Schedule	Maintenance item
Before start- up	Follow section 9 in this document
After 1 week	Inspect seals Inspect drive motor Inspect drive belt and it's tension
6 months after commissioning (4320 hours in operation)	Tension the tension bolts Inspect seals Inspect drive motor Inspect drive belt and it's tension
Twice Yearly	Inspect seals Inspect drive motor Inspect drive belt and it's tension
Once Yearly	Measure pressure drop over the rotor. Pressure drop > 1.25 × New = Clean the rotor

Rotor inspection

Bearings supplied are permanently lubricated and require no additional maintenance. Carefully inspect the face of the rotor for signs of damage, dirt or contamination build up.

Seal inspection

Inspect the condition of the seals to ensure a positive seal between the rotor face and metallic frame structure. The seals should be intact and should slightly contact the casing / cassette structure or flanges, and face of the rotor media. Closely inspect the seals for excessive wear, especially the dividing seals between supply and exhaust air. If excessive wear is evident, the seals should be scheduled for replacement. Also inspect to ensure a good seal exists between the metallic structure of the casing / cassette and interconnecting duct work. Any significant leakage in these areas affect overall performance and should be sealed.

Drive inspection

Drive motors are permanently lubricated and require no additional maintenance. Inspect the drive system to ensure all hardware is secure, the pulley is secured to the motors shaft and that there is no significant misalignment of the drive belt on the pulley or periphery of the rotor. Check that the belt joint is in good condition, if not schedule for replacement. Check that drive belt is tensioned (taut), if not schedule for maintenance. Check that the whole length of the drive belt is in good condition, if not schedule for replacement asap.

Original spare parts

Always use original spare parts, please contact your salesman or send your requirements to info@ca-ostberg.com.

LIMITED WARRANTY

Seller warrants to the original Purchaser of its Energy Recovery Rotors and Cassettes (“Products”), subject to the enclosed exclusions and conditions, that the Products will be free from defects in materials and workmanship as described herein.

1. **Rotor and Cassette metallic structure** including hub, shaft, spokes, perimeter band, cassette sheet metal and tubing structures (as applicable) are warranted for a period of twenty-four (24) months from the date of shipment, and are specifically warranted, in addition to being free of defects in material and workmanship, for the following:
 - a) Structures including welds and base materials shall not fail due to corrosion from normal ambient sources (corrosive industrial environments are excluded).
 - b) Structures shall not fail due to normal operating pressures and subsequent developed stresses.

2. **Media and Substrate** are warranted for a period of twenty-four (24) months from the date of shipment, and are specifically warranted, in addition to being free of defects in material and workmanship, for the following:
 - a) Material will not fail operating under normal conditions, normal conditions is equal to conditions accepted in the sellers calculation software at time for purchasing.
 - b) If installed and operated in accordance with the manufacturer’s instructions, media shall perform as per data published by the manufacturer.

3. **Additional components** such as rotor bearings & drive motors are warranted for period of 24 months from the date of shipment and are specially warranted, in addition to being free of defects in material and workmanship, for the following:
 - a) Equipment shall not fail due to insufficient torque and or rusty for selected application.
 - b) Material will not wear to the point of failure within the period from normal operating stresses.

4. **Additional components** such as seals, belts, sprockets and controls (as applicable) are warranted for period of 12 months from the date of shipment and are specially warranted, in addition to being free of defects in material and workmanship, for the following:
 - a) Material will not wear to the point of failure within the period from normal operating stresses.

Seller's sole obligation under this Limited Warranty, is to repair or replace, at its option, free of charge to the original purchaser (except as noted), F.C.A. the Seller's factory, any Product determined by the Seller (in its sole discretion) to be defective. Seller's Limited Warranty excludes defects, failures and reduced performance caused, either directly or indirectly, by improper installation, abuse, misuse, misapplication, improper maintenance, lack of maintenance, negligence, accident or normal deterioration, including wear and tear. This Limited Warranty additionally shall not apply to failures, defects or reduced performance, resulting either directly or indirectly, from any use or purpose other than energy recovery (as applicable), or from exposure to corrosive environments (liquid or gaseous) or liquid water, in the form of impingement from a moving air stream. This limited Warranty additionally excludes damages due to natural disasters and Force Majeure. This Limited Warranty does not include costs for transportation (including without limitation, freight and return freight charges, costs and insurance), cost from removal or re-installation of parts or equipment, premiums for overtime, or labor for performing repairs or replacement to equipment in the field. Seller is not responsible for damages during transport of any product to or from Seller's location. THE OBLIGATION AND LIABILITY OF THE SELLER UNDER THIS LIMITED WARRANTY DOES NOT INCLUDE LOSSES, DIRECT OR INDIRECT, FOR INCIDENTAL, SPECULATIVE, INDIRECT, OR CONSEQUENTIAL DAMAGES, RESPECTIVE OF THE FORSEEABILITY OF ANY SUCH DAMAGES. THIS LIMITED WARRANTY IS PROVIDED EXCLUSIVELY TO THE ORIGINAL PURCHASER OF PRODUCTS AND MAY NOT BE TRANSFERRED OR ASSIGNED WITHOUT THE EXPRESS WRITTEN CONSENT OF THE SELLER. THIS LIMITED WARRANTY IS IN LIEU OF, AND SELLER HEREBY EXPRESSLY DISCLAIMS, ALL OTHER WARRANTIES, EXPRESS OR IMPLIED, INCLUDING WITHOUT LIMITATION, ANY WARRANTIES OF MERCHANTABILITY AND FITNESS FOR A PARTICULAR PURPOSE, AND THERE ARE NO WARRANTIES WHICH EXTEND BEYOND THE DESCRIPTION ON THE FACE HEREOF.

In no event, shall the Seller's liability to Purchaser hereunder, or in any respect of the transactions contemplated hereby, whether direct or indirect, exceed the amount paid by the Purchaser in respect of the products from which any such liability is said to arise.

energy
efficient
ventilation

ÖSTBERG 

Östberg (Kunshan) Ventilation Co., Ltd

426 Kunjia Road, Kunshan, Jiangsu Province, China

Tel: +86 512 57639555
Service.china@ca-ostberg.com
www.ostberg.com

2506000103_utg01